

DISCUSSION PAPERS IN ECONOMICS

Working Paper No. 00-02

GTAP-Energy in GAMS:
The Dataset and Static Model

Thomas F. Rutherford

*Department of Economics, University of Colorado at Boulder
Boulder, Colorado*

Sergey V. Paltsev

*Department of Economics, University of Colorado at Boulder
Boulder, Colorado*

February 2000

Center for Economic Analysis
Department of Economics



University of Colorado at Boulder
Boulder, Colorado 80309

© 2000 Thomas F. Rutherford, Sergey V. Paltsev

GTAP-Energy in GAMS: The Dataset and Static Model

Thomas F. Rutherford and Sergey V. Paltsev

Department of Economics, University of Colorado †

Working Paper No. 00-2

February 2000

Abstract

The paper documents the energy-economy dataset GTAP-EG which is based on the general Global Trade Analysis Project (GTAP) database and OECD International Energy Agency (IEA) statistics. The GTAP-EG dataset is developed in collaboration with the researchers at Purdue University, who created a GEMPACK version of the energy dataset. In contrast to their work, the GTAP-EG is implemented in the GAMS programming language using a different calibration procedure. An illustrative static model in MPSGE syntax complements the GTAP-EG. Having the dataset in GAMS is helpful for researchers because of its open-architecture approach which permits to modify easily the dataset and the model for their own purposes. The document contains a description and directions for installing and using the GAMS-EG dataset. The paper also helps to quantify the extent to which the calibration method affects the data.

*Financial support from the United States Department of Energy is greatly acknowledged. The authors can be reached at: rutherford@colorado.edu, sergey.paltsev@colorado.edu

†University of Colorado, Department of Economics, Boulder, CO 80309-0256, USA.

1 Introduction

The purpose of the paper is to provide an easily accessible set of energy-economic statistics to researchers working on environment-trade related issues. Modellers who conduct quantitative analysis of international trade issues in an economy-wide framework often use the Global Trade Analysis Project (GTAP) database (Hertel [1997]). The GTAP is a research program initiated in 1992 at Purdue University to provide the economic research community with a global economic dataset for use in the quantitative analyses of international economic policy. The GTAP version 4 database represents global production and trade for 45 country/regions, 50 commodities and 5 primary factors. The data characterize intermediate demand and bilateral trade in 1995, including tax rates on imports and exports. The GTAP data alone, however, are unsuitable for assessing

all three data sources (GTAP economic data, IEA energy quantities, and price data) has been changed in the process of calibration. The standard programming language for GTAP data and modeling work has been GEMPACK (Harrison and Pearson [1996]).

In contrast to Purdue approach, we apply standard optimization techniques for calibrating the GTAP data to energy statistics. The resulting dataset which is described in this paper called GTAP-EG (GTAP-Energy in GAMS). Accordingly, the dataset and an illustrative model are

Table 1: Regional Identifiers in the Full GTAP-EG Dataset

SET	Regions /
AUS	Australia,
NZL	New Zealand,
JPN	Japan,
KOR	Republic of Korea,
IDN	Indonesia,
MYS	Malaysia,
PHL	Philippines,
SGP	Singapore,
THA	Thailand,
VNM	Vietnam,
CHN	China,
HKG	Hong Kong,
TWN	Taiwan,
IND	India,
LKA	Sri Lanka,
RAS	Rest of South Asia,
CAN	Canada,
USA	United States of America,
MEX	Mexico,
CAM	Central America and Caribbean,
VEN	Venezuela,
COL	Colombia,
RAP	Rest of Andean Pact,
ARG	Argentina,
BRA	Brazil,
CHL	Chile,
URY	Uruguay,
RSM	Rest of South America,
GBR	United Kingdom,
DEU	Germany,
DNK	Denmark,
SWE	Sweden,
FIN	Finland,
REU	Rest of EU,
EFT	European Free Trade Area,
CEA	Central European Associates,
FSU	Former Soviet Union,
TUR	Turkey,
RME	Rest of Middle East,
MAR	Morocco,
RNF	Rest of North Africa,
SAF	South Africa,
RSA	Rest of South Africa,
RSS	Rest of Sub-Saharan Africa,
ROW	Rest of World /;

Table 1 presents regional identifiers of the full GTAP-EG dataset. An aggregation of 135 IEA-format regions into 45 GTAP regions is shown in Appendix 2. Most of the regional identifiers in the dataset correspond to standard UN three-character country codes⁴.

To combine energy and trade data, 32 IEA-format sectors are aggregated into 22 sectors. In order to comply with IEA aggregation, the original 50 industrial sectors of GTAP data are also aggregated into the same 22 sectors. A sector for the investment composite is added to the original GTAP-GEMPACK representation. Table 2 presents the identifiers for the 23 GTAP-EG sectors. The sectoral identifiers for energy are different from the GTAP-E-FIT identifiers⁵. The differences are noted in Table 3.

A concordance between IEA, GTAP 4, and GTAP-EG production sectors is presented in Appendix 3. The process of incorporating IEA statistics into GTAP-EG format is described in detail in Rutherford and Paltsev [2000]. Sectors may be aggregated to produce more compact datasets. The aggregation routine is described in Section 4.

Table 4 presents the three-character identifiers used for primary factors. Note that these differ from the primary factor names employed in the GEMPACK model.

The GTAP data describe economic transactions in 1995. All parameters in GTAP are expressed in terms of values (i.e. price times quantity). Units of account in GTAP in its original GEMPACK representation (and GTAP-E-FIT) are millions of 1995\$. The units in GTAP-EG are different by

⁴Users can define their own aggregations of the GTAP data and use any labels to describe regions. For technical reasons, if a GTAP dataset is to be used with MPSGE, then regional identifiers can have at most four characters.

⁵GTAP-E-FIT has the same identifiers as the GTAP4 dataset.

Table 2: Sectoral and Primary Factors Identifiers in the Full GTAP-EG Dataset

Set I Sectors and goods /
 GAS Natural gas works
 ELE Electricity and heat
 OIL Refined oil products
 COL Coal
 CRU Crude oil

I_S Iron and steel industry
 CRP Chemical industry
 NFM Non-ferrous metals
 NMM Non-metallic minerals
 TRN Transport equipment
 OME Other machinery
 OMN Mining
 FPR Food products
 PPP Paper-pulp-print
 LUM Wood and wood-products
 CNS Construction
 TWL Textiles-wearing apparel-leather
 OMF Other manufacturing
 AGR Agricultural products
 T_T Trade and transport
 SER Commercial and public services
 DWE Dwellings,
 CGD Investment composite /;

Set f Primary Factors /
 LND Land
 SKL Skilled Labor
 LAB Unskilled Labor
 CAP Capital
 RES Natural Resources /;

Table 3: Differences between GTAP-E-FIT and GTAP-EG sectoral identifiers.

Sector	GTAP-E-FIT	GTAP-EG
Electricity and heat	ELY	ELE
Refined oil products	P_C	OIL
Crude oil	OIL	CRU

Table 4: Differences between GTAP-E-FIT and GTAP-EG primary factor identifiers.

Sector	GTAP-E-FIT	GTAP-EG
Land	Land	LND
Skilled labor	SkLab	SKL
Unskilled labor	UnSkLab	LAB
Capital	Capital	CAP
Natural resources	NatRes	RES

a factor of 10,000. GTAP-EG measures transactions in tens of billions of 1995\$. Scaling units in this way assures better numerical precision in equilibrium calculations.

GAMS statements which declare all parameters in a GTAP-EG dataset are shown in Table 5. The GTAP-EG dataset has a similar structure to GTAPinGAMS (Rutherford [1998]) with the addition of energy quantities. The parameters beginning with ``v' ' are base year (1995) value data, most of which are from the original GEMPACK implementation of GTAP. Not all value data from the original dataset are included here. The principal difference is that the GTAP-EG dataset stores tax *rates* rather than gross and net of tax transaction values as in the GEMPACK implementation. The tax parameters, beginning with ``t' ' are not in the original GEMPACK dataset.

The energy parameters, beginning with ``e' ' are in neither the original GTAP nor in the GTAPinGAMS dataset. Energy prices can be recovered by division of the respective values by

Table 5: Parameters Explicitly Represented in a GTAP-EG Dataset

alias (i, j), (r, s);

PARAMETER

ty(i, r)	Output tax
ti(j, i, r)	Intermediate input tax
tf(f, i, r)	Factor tax
tx(i, s, r)	Export tax rate (defined on a net basis)
tm(i, s, r)	Import tariff rate
tg(i, r)	Tax rates on government demand
tp(i, r)	Tax rate on private demand
vafm(j, i, r)	Aggregate intermediate inputs
vfm(f, i, r)	Value of factor inputs (net of tax)
vxmd(i, r, s)	Value of commodity trade (fob - net export tax)
vtwr(i, r, s)	Transport services
vst(i, r)	Value of international transport sales
vdgm(i, r)	Government demand (domestic)
vigm(i, r)	Government demand (imported)
vdpm(i, r)	Aggregate private demands (domestic)
vipm(i, r)	Aggregate private demands (domestic);
ei nd(i, i, r)	Industrial energy demand (EJ&TKWH),
efd(i, r)	Final energy demand (EJ&TKWH),
eexp(i, r)	Energy exports (EJ&TKWH),
ei mp(i, r)	Energy imports (EJ&TKWH),

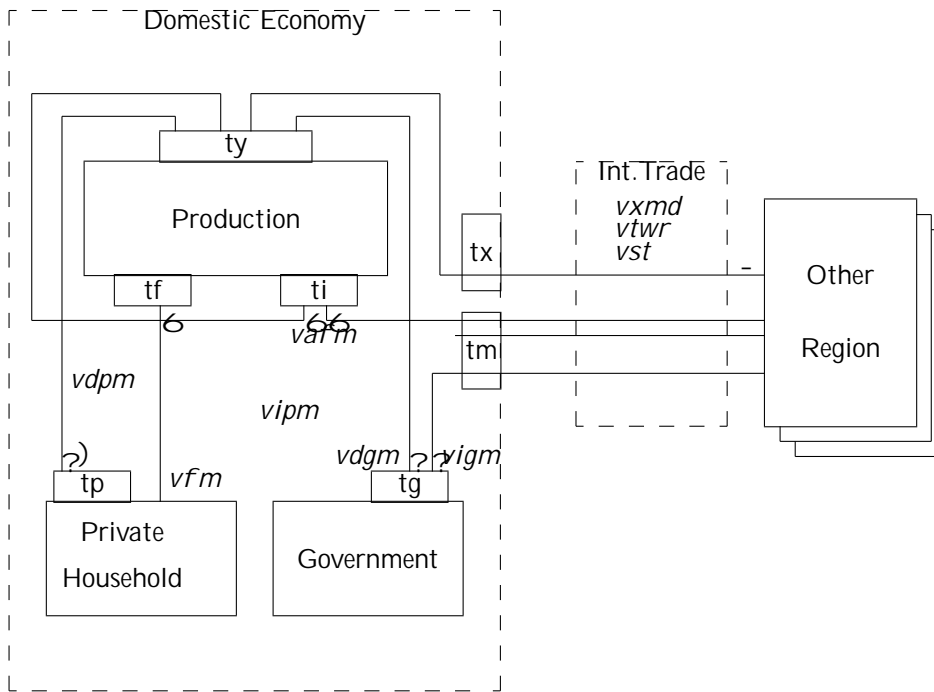

Fig. 1. GTAP flows explicitly represented in the dataset.

Whenever the GTAP-EG dataset is read, additional intermediate parameter values are assigned. Declarations for the computed parameters are presented in Table 6. Table 7 lists the GAMS parameter assignment statements for the computed items. Briefly, this is done as follows: (i) aggregate exports at market prices (v_{xm}) are defined from the matrix of bilateral trade flows; (ii) aggregate imports at market prices (v_{im}) are defined by bilateral exports, export taxes, transportation margins and tariff rates; (iii) domestic output (v_{dm}) is determined as a residual through the zero profit condition; (vi) domestic supply to the intermediate demand (v_{dfm}) is defined as a residual given domestic production and other demands for domestic output; (vii) import supply to intermediate demand (v_{ifm}) is also defined as a residual given aggregate imports, private and public import demand. This sequence of assignments implies that any imbalance in the dataset shows up as either a discrepancy in the demand and supply for intermediate inputs or as an imbalance between demand and supply of transportation services. The parameter market is created to generate a report of consistency of the benchmark data. Primary factor markets always balance because endowments are computed residually given benchmark factor demands across sectors. Likewise, regional current account balances are computed from the income-expenditure identity.

Table 8 lists declarations and assignments of reference prices for each of the benchmark transactions which are subject to tax. These parameters are used in the GAMS model as part of the calibration of demand functions. For more discussion about the GAMS implementation of the static model, see Section 3.

2.2 The GTAP-EG Dataset: Basic Statistics

A summary of economic activity by production sectors and regions in the GTAP-EG dataset is presented in Appendix 4. These numbers differ slightly from GTAP-E-FIT dataset⁷. The two energy datasets are different even though they are based on the same initial data, such as the GTAP version 4 (Hertel [1997]) expressed in terms of values (i.e. price times quantity), OECD International Energy Agency statistics (Complainville [1998]) expressed in terms of quantity, and

⁷A summary of economic activities from GTAP-E-FIT dataset can be found at <http://debreu.colorado.edu/download/gtap-eg.html>

Table 6: Computed Benchmark Parameters

parameter	
$vim(i, r)$	Total value of imports (gross tariff)
$vxm(i, r)$	Value of export (gross excise tax)
$vdm(i, r)$	Value of domestic output (net excise tax)
$vdfm(i, r)$	Aggregate intermediate demand (domestic)
$vi fm(i, r)$	Aggregate intermediate demand (imported)
$vom(i, r)$	Aggregate output value (gross of tax)
$vgm(i, r)$	Public expenditures
$vpm(i, r)$	Private expenditures
$vg(r)$	Total value of public expenditure
$vp(r)$	Total value of private expenditure
$vi(r)$	Total value of investment
vt	Value of international trade margins
$vb(*)$	Net capital inflows
$market(*, *)$	Consistency check for calibrated benchmark
$evoa(f, r)$	Value of factor income
$va(d, i, r)$	Armington supply
$vd(d, i, r)$	Domestic supply
$vm(d, i, r)$	Imported supply;

energy price and tax data (Babiker and Malcolm [1998]). The reason for this discrepancy is the different calibration procedures that have been used. Since only two out of three variables (price, quantity, value) can be regarded as independent, it is problematic to incorporate both price and quantity data into the GTAP database.

The GTAP-EG approach is to preserve the IEA energy quantity statistics and most of the prices and adjust the GTAP values. In contrast, the GTAP-E-FIT energy dataset is created using the procedure where the information from all three data sources has been changed in the process of calibration (Malcolm and Truong [1999]). The GTAP-EG and GTAP-E-FIT datasets have some differences in the parameter values for several regions. To illustrate the difference, we calculate carbon dioxide emissions and then compare the results with the IEA [1997] publication where the carbon dioxide emissions from fuel combustion are reported. It should be noted that the results from the IEA publication [1997] and the IEA statistics collected by Complainville are different. One source of the difference is International Marine Bunkers which are present in IEA book but not in the datasets. The International Marine Bunkers contains emissions from fuels burned by sea-going ships of all flags that are engaged in international transport. These emissions are excluded from national totals in IEA publication. As a result, the data for countries with big sea fleet differs substantially.

The CO_2

Table 7: Assignments for Computed Benchmark Parameters

```

vxm(i, r) = sum(s, vxmd(i, r, s)) + vst(i, r);

vi m(i, r) = sum(s, (vxmd(i, s, r)*(1+tx(i, s, r))+vtwr(i, s, r))*(1+tm(i, s, r)));

vdm(i, r) = ( sum(j, vafm(j, i, r)*(1+ti(j, i, r)))
              + sum(f, vfm(f, i, r)*(1+tf(f, i, r)))) / (1-ty(i, r)) - vxm(i, r);

vdfm(i, r) = vdm(i, r) - vdgm(i, r) - vdpm(i, r) - vdm(i, r)$cgd(i);

vi (r) = sum(cgd, vdm(cgd, r));

vi fm(i, r) = vi m(i, r) - vi pm(i, r) - vi gm(i, r);

vom(i, r) = vdm(i, r) + vxm(i, r);

vgm(i, r) = vi gm(i, r)+vdgm(i, r);

vpm(i, r) = vi pm(i, r)+vdpm(i, r);

vg(r) = sum(i, vgm(i, r) * (1 + tg(i, r)));

vp(r) = sum(i, vpm(i, r) * (1 + tp(i, r)));

vt = sum((i, r), vst(i, r));

evoa(f, r) = sum(i, vfm(f, i, r));

vb(r) = vp(r) + vg(r) + vdm("cgd", r)
        - sum(f, evoa(f, r))
        - sum(i, ty(i, r) * vom(i, r))
        - sum((i, j), ti(j, i, r) * vafm(j, i, r))
        - sum((i, f), tf(f, i, r) * vfm(f, i, r))
        - sum((i, s), tx(i, r, s) * vxmd(i, r, s))
        - sum((i, s), tm(i, s, r) * (vxmd(i, s, r)*(1+tx(i, s, r)) + vtwr(i, s, r)) )
        - sum(i, tg(i, r)*vgm(i, r))
        - sum(i, tp(i, r)*vpm(i, r));

vm("c", i, r) = vi pm(i, r);          vd("c", i, r) = vdpm(i, r);
vm("g", i, r) = vi gm(i, r);          vd("g", i, r) = vdgm(i, r);
vm("i", i, r) = vi fm(i, r);          vd("i", i, r) = vdfm(i, r);
va(d, i, r) = vm(d, i, r) + vd(d, i, r);
market(r, i) = vdfm(i, r) + vi fm(i, r) - sum(j, vafm(i, j, r));
market("world", "t") = vt - sum((i, r, s), vtwr(i, r, s));

```

Table 8: Benchmark Prices

parameter

$pc0(i, r)$	Reference price index for private consumption
$pf0(f, i, r)$	Reference price index for factor inputs
$pg0(i, r)$	Reference price index for public
$pi0(j, i, r)$	Reference price index for intermediate inputs
$pt0(i, s, r)$	Reference price index for transport
$px0(i, s, r)$	Reference price index for imports;

$$px0(i, s, r) = (1+tx(i, s, r))*(1+tm(i, s, r));$$

$$pt0(i, s, r) = 1+tm(i, s, r);$$

$$pc0(i, r) = 1+tp(i, r);$$

$$pg0(i, r) = 1+tg(i, r);$$

$$pi0(j, i, r) = 1+ti(j, i, r);$$

$$pf0(f, i, r) = 1+tf(f, i, r);$$

Table 9: Carbon dioxide emissions (selected countries) - billion of tonnes

	IEA book	IEA stat	E-FIT	EG before x	EG
JPN	1.151	1.208	1.145	1.257	1.257
KOR	0.353	0.449	0.396	0.449	0.449
SGP	0.059	0.085	0.085	0.085	0.085
CHN	3.007	3.098	2.902	3.112	3.112
IND	0.803	0.771	0.765	0.773	0.773
CAN	0.471	0.505	0.472	0.506	0.506
USA	5.228	5.339	5.175	5.340	5.460
MEX	0.328	0.328	0.309	0.328	0.328
BRA	0.287	0.269	0.256	0.289	0.289
GBR	0.565	0.605	0.540	0.607	0.607
DEU	0.884	0.973	0.865	0.973	0.973
REU	1.560	1.734	1.628	1.735	1.735
FSU	2.483	2.542	2.341	2.549	2.549
RME	0.817	0.788	0.755	0.827	0.827
ROW	0.518	0.208	0.183	0.208	0.208
total	22.150	22.482	21.272	22.644	22.764

goods. Energy trade involves primarily crude oil and coal which can be exported or imported in international markets.

The core model described here is a static, multi-regional model which tracks the production and distribution of goods in the global economy. The model is an Arrow-Debreu general economic equilibrium model concerning the interaction of consumers and producers in markets. Lars Mathiesen [1985] proposed a representation of this class of models in which two types of equations define an equilibrium: zero profit and market clearance. The corresponding variables defining an equilibrium are activity levels (for constant-returns-to-scale firms) and commodity prices.⁹

Commodity markets merge primary endowments of households with producer outputs. In equilibrium the aggregate supply of each good must be at least as great as total intermediate and final demand. Initial endowments are exogenous. Producer supplies and demands are defined by producer activity levels and relative prices. Final demands are determined by market prices.

Economists who have worked with conventional textbook equilibrium models can find Mathiesen's framework to be somewhat opaque because many quantity variables are not explicitly specified in the model. Variables such as final demand by consumers, factor demands by producers and commodity supplies by producers, are defined implicitly in Mathiesen's model. For example, given equilibrium prices for primary factors, consumer incomes can be computed, and given income and goods prices, consumers' demands can then be determined. The consumer demand functions are written down in order to define an equilibrium, but quantities demanded need not appear in the model as separate variables. The same is true of inputs or outputs from the production process: relative prices determine conditional demand, and conditional demand times the activity level represents market demand. Omitting decision variables and suppressing definitional equations corresponding to intermediate and final demand provides significant computational advantages at the cost of a somewhat more complex model statement.

The flows represented in Figure 2 are implemented in the GTAP-EG model in the following way. In the model there are two types of produced commodities, fossil-fuel and non-fossil fuel commodities. The model assumes that goods produced in different regions are qualitatively distinct (Armington [1968]). This implies that trade in goods is represented as flows between pairs of countries rather than from individual countries and an integrated global market. Every bilateral trade flow requires its own transportation services. Primary factors in each region include labor, capital and fossil-fuel resources. Labor is mobile within domestic borders but cannot move between regions. Capital can be global or region-specific. Natural resources are sector-specific.

Now we turn to a formulation of the GTAP-EG model in MPSGE format. The MPSGE framework is based on nested constant elasticity of substitution utility functions and production functions. MPSGE uses a concept of representing these functions as separate "blocks". We describe the basic blocks only. Some exception operators are omitted here to make the code easier to read¹⁰. Appendix 5 contains listing of the GAMS-MPSGE code.

In the GTAP-EG model an economy in region r consists of three production blocks. The block $y(i;r)$ is related to production, where fossil-fuel production has a different structure from other production sectors. We implicitly introduced a production block for Armington supply which represents an aggregation between domestic and import varieties and across imports from different trading partners. Armington aggregation is described by the block $a(i;r)$. Armington supply is used then for private consumption and as an intermediate input to production. Private consumption is presented by the block $c(r)$. Finally, a production block yt describes the provision of international transport services.

In order to represent consumption, another class of the MPSGE variables is introduced. In

⁹Under a maintained assumption of perfect competition, Mathiesen may characterize technology as CRTS without loss of generality. Decreasing returns are accommodated through introduction of a specific factor, while increasing returns are inconsistent with the assumption of perfect competition. In this environment zero excess profit is consistent with free entry for atomistic firms producing an identical product.

¹⁰GAMS has a special operator used for exception handling. It is denoted as a dollar sign. The exception operator is very useful, for example, in the cases when we want to represent some sectors of an economy which may not be active in a benchmark. For more information, see GAMS User's Guide.

each region the representative agent (described by a consumption block $ra(r)$) depicts a collective decision process for allocating income to households and to a government. Both $c(r)$ and $ra(r)$ MPSGE blocks are needed because national consumption is taxed and taxes cannot be imposed on a demand block.

Regions may apply domestic carbon taxes. Carbon tax revenue is collected by the representative agent in each region. Within this model, the carbon tax policy is equivalent to an emission permit system where the permit price coincides with the carbon tax. There are also taxes on output ty , intermediate inputs ti , consumption tc , export tx , and import tm . Figure 3 depicts the structure of the GTAP-EG model.

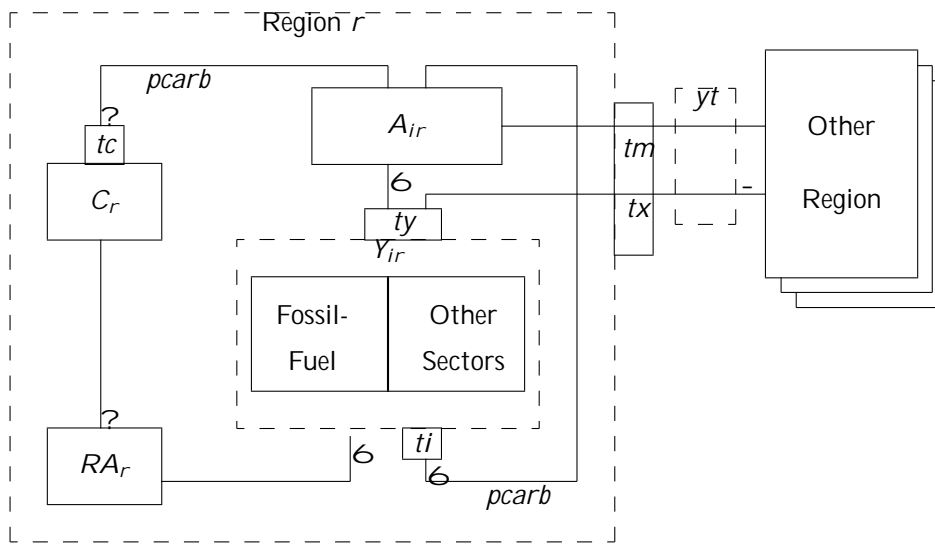

Fig. 3. Structure of the GTAP-EG model.

An MPSGE model is specified by endogenous variable declarations and a sequence of function "blocks", one for each production sector and consumer in the model. A declaration of the GTAP-EG variables is presented below. Key words in the declaration as follows. $\$SECTORS$: describes production activities that convert commodity inputs into commodity outputs. The variable associated with a sector is the activity level. $\$COMMODITIES$ are related to a good or factor. The variable associated with a commodity is its price, not its quantity. $\$CONSUMERS$ denote individuals who demand commodities, supply factors and receive tax and other revenues.

pt

! Transport services

and reference price ($p : \text{eld}$). If a reference price is equal to zero, then the price eld can be omitted. The nesting structure consists of two nests with top level elasticity equal to $s : \text{esub_es}$, and the elasticity between intermediate and labor inputs equals 0 ($id : 0$).

Output taxes ty

s: 0
A@
A @
A @
A @
Non-energy inputs

@
@
@

composite enters into production differently for different sectors. The line $i : pa(j; r) \text{ } (not fe(j))$ defines it for non-fossil energy sectors, where fe denotes a set of fossil energy (oil, coal, gas). The top level elasticity (s_i) equals to zero. It has a subnest $vae(s)$, which in turn has two subnests $va(vae)$ and $e(vae)$. An elasticity e

The Armington supply block also applies transportation margins which are proportional to quantities traded. The $i : pt\#(s)$ input represents multiple inputs of transportation services, one for each element of set s . There are multiple inputs of transportation services into each imported good because every bilateral trade flow demands its own transportation services. Using a Leontief aggregate on each bilateral trade flow assures that transport costs and imports remain strictly proportional to the base year level.

* Armington aggregation over domestic versus imports:

```

$prod: a(i, r) $a0(i, r) s: 4 m: 8 s. tl (m): 0
o: pa(i, r) q: a0(i, r)
i: py(i, r) q: d0(i, r)
i: py(i, s) q: vxmd(i, s, r) p: pmx0(i, s, r) s. tl:
+ a: ra(s) t: tx(i, s, r) a: ra(r) t: (tm(i, s, r)*(1+tx(i, s, r)))
i: pt#(s) q: vtwr(i, s, r) p: pmt0(i, s, r) s. tl: a: ra(r) t: tm(i, s, r)

```

3.3 International Transport

The international transport services are assumed to be a Cobb-Douglas composite of goods provided in the domestic markets in each region, as shown in Figure 7.

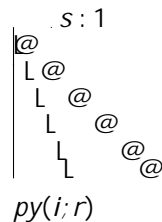

Fig. 7. International transport services

The MPSGE representation shows yt as a Cobb-Douglas ($s : 1$) composite of goods provided in the domestic markets of each region.

* International transport services (Cobb-Douglas):

```

$prod: yt s: 1
o: pt q: (sum((i, r), vst(i, r)))
i: py(i, r) q: vst(i, r)

```

3.4 Final Demand

Final demand has the structure shown in Figure 8. Utility in each country is a constant elasticity aggregate of non-energy consumption and energy. The non-energy composite is in turn a Cobb-Douglas aggregate of different goods while final energy is a Cobb-Douglas aggregate of electricity, oil, gas, and coal.

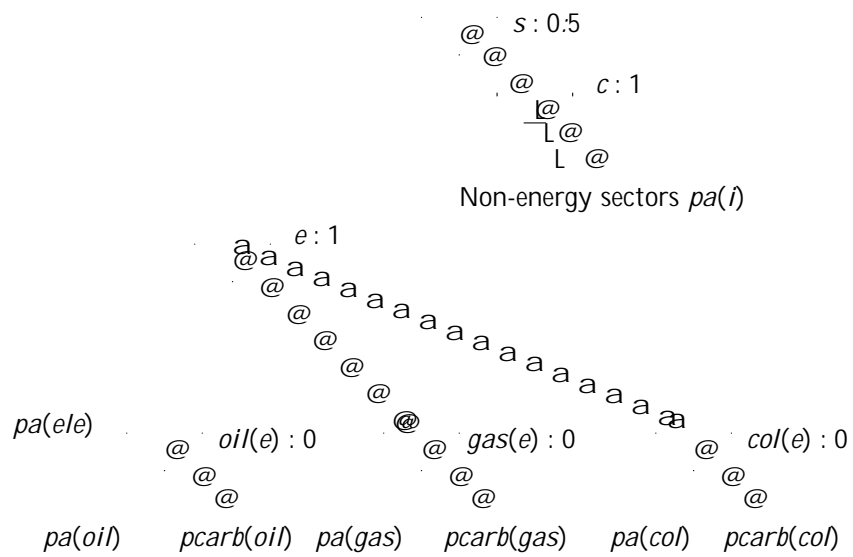

Fig. 8. Final demand

Final consumption in region r is characterized by activity $c(r)$, which is a constant elasticity aggregate ($s: 0$):

3.5 An Illustrative Calculation: Leakage Rate

In this section we show a calculation of a leakage rate based on the GTAP-EG model. The leakage rate is defined as the ratio of total carbon emissions by non-Annex B countries to total emissions abatement by the Annex B. This means that if the leakage rate is 50%, then a decrease in carbon emissions by the Annex B countries of 100 million tons will lead to the increase in carbon emissions by the non-Annex B countries of 50 million tons.

The formula for the leakage rate is

$$LeakageRate = \sum_n 100 \frac{CARB_{1,n} - CARB_{0,n}}{CARB_{0,m} - CARB_{1,m}} \quad (1)$$

where n denotes the non-Annex B countries, m represents the Annex B, $CARB_0$

MPSGE subsystem

LIBINCLUDE Tools for Writing GAMS-Readable Data Files (optional)¹⁴

A Pentium computer running Windows 95 or NT with more than 100 MB of free disk space.

4.2 Download

The GAMS-EG package is distributed in a zip archive (gtap-eg.zip) file. You can download it from <http://debreu.colorado.edu/download/gtap-eg.zip>. The archive has the directory structure presented in Table 10.

After downloading the file gtap-eg.zip into your computer, unzip the file making sure that the archive's directory structure is preserved¹⁵. The GTAP-EG dataset has two versions: full (aspen.zip) and aggregated (aspen_small.zip). In order to get the full version, a user needs to run the build routine ASPEN.BAT described below. The aggregated dataset is created for testing purposes. It is located in the DATA subdirectory and ready to use. A description of the aggregated dataset is given below.

4.3 The build routine ASPEN.BAT

The GTAP-EG dataset is built on the standard GTAP-4 database, which is not distributed freely. In order to construct the full GTAP-EG dataset, a user needs to contact GTAP at <http://www.agecon.purdue.edu/gtap/> to obtain the GTAP4 dataset (the file gsddat.har).

The file gsddat.har needs to be placed into the DATA subdirectory. To create the full version of GTAP-EG, a user needs to run aspen.bat file¹⁶, which is described below.

The file aspen.bat is intended to:

Read gsddat.har file.

Convert gsddat.har into gtap.gms.

Relabel and scale the data to create gtap.zip.

Filter and recalibrate the data to gtap001.zip.

Aggregate to a dataset compatible with the IEA data: iea.zip.

Calibrate the GTAP and IEA energy data to create gtap1000.zip.

Relabel the energy commodities, translating gtap1000.zip to aspen.zip.

Delete work files.

Give to a user an option of creating the aggregated GTAP-EG dataset and running an illustrative model.

Aggregate to 13x8, include energy projections and create aspen_small.zip
Will aggregate to aspen_small.zip:
Press any key to continue . . .

If you press any key, then in addition to the full dataset an aggregated dataset will be created (a new file aspen_small.zip will replace an old one) and an illustrative model will run on an aggregated data. If you press "\Ctrl-C", then the following message appears.

Terminate batch job (y/n)?

If you terminate the batch job at this time (by pressing "\y" and then "\Enter"), aspen.bat will stop and only the full version of the GTAP-EG dataset will be created and placed into DATA subdirectory under the name aspen.zip.

In the process of building the dataset, several echo files are placed in the ASPEN subdirectory:

iea.ech - Report on economic activity by sector and region from GTAP data;

energy1000.ech - Energy statistics;

aspen.ech - Report on economic activity by sector and region from the full GTAP-EG dataset;

aspen_small.ech - Report on economic activity by sector and region from the aggregated GTAP-EG dataset.

4.4 Aggregation

Once you have built the initial GTAP-EG dataset aspen.zip, you can begin to think about a particular application and which aggregations of the original GTAP-EG data would be appropriate for studying those issues. Typically it is useful to create two aggregations for any new model, one with a minimal number of regions and commodities and another with a larger number of dimensions. The small aggregation can then be used for model development.

The gtapaggr.bat program is used to aggregate a GTAP-EG dataset. A command line argument defines the name of the target aggregation. You only need to provide the batch file with the target because the target's mapping file defines the source. Before running gtapaggr.bat, you must create two files, one defining the sets of commodities, regions and primary factors in the

Step 3. Running the aggregation routine. To run the aggregation routine, go to ASPEN subdirectory, type `gtapaggr aspen_small` at MS-DOS prompt, and press \Enter". The target dataset `aspen_small.zip` will be placed in the DATA subdirectory¹⁸. Now you can define your own SET and MAP and create your own aggregated datasets using `gtapaggr.bat`. It should be noted that the aggregation routine also includes the energy projections into the aggregated dataset if the source file is `aspen.zip`.

4.5 An aggregated 13x8 dataset: ASPEN_SMALL.ZIP

The GTAP-EG.ZIP archive contains an aggregated version of GTAP-EG. It is located in DATA subdirectory and named ASPEN_SMALL.ZIP. The archive contains the data file ASPEN_SMALL.GMS, and associated SET and MAP files. The aggregated dataset has 13 regions, 8 goods, and two primary factors. The identifiers for the aggregated dataset are contained in the SET file, which is provided in Appendix 6. Basic statistics from the ASPEN_SMALL dataset is presented in Table 11.

Table 11. Basic statistics from the aggregated GTAP-EG dataset

CO2 inventories (IEA)-- mton

	total	ind_nele	fd_nele	electric	ind_total	fd_total	kg/\$
USA	1489.2	613.2	337.1	539.0	1014.5	474.8	0.2
CAN	138.1	83.9	28.6	25.6	104.1	34.0	0.3
EUR	981.7	515.6	225.7	240.4	705.3	276.4	0.1
JPN	342.8	198.3	54.8	89.7	269.7	73.0	0.1
OOE	86.7	39.9	11.0	35.8	68.0	18.7	0.2
FSU	695.1	324.6	72.3	298.2	576.6	118.5	1.8
CEA	208.1	91.3	25.0	91.8	167.2	40.9	0.8
CHN	912.4	570.5	83.7	258.2	798.2	114.2	1.0
IND	210.9	88.1	26.4	96.4	172.4	38.5	0.8
BRA	78.9	61.5	14.1	3.3	64.2	14.7	0.1
ASI	254.0	158.9	39.0	56.1	205.5	48.5	0.3
MPC	435.8	260.4	77.3	98.1	338.8	97.0	0.5
ROW	374.9	212.2	60.2	102.5	296.6	78.3	0.3
total	6208.5	3218.4	1054.9	1935.1	4781.2	1427.3	

Sectoral CO2 intensities --kg per \$output

	Y	EIS	ELE
USA	0.1	0.2	2.0
CAN	0.1	0.2	0.8
EUR		0.1	0.9
JPN		0.1	0.4
OOE	0.1	0.3	2.4
FSU	0.6	1.5	6.6
CEA	0.2	0.6	4.1
CHN	0.2	0.9	5.2
IND	0.2	1.0	3.4
BRA		0.1	0.2

¹⁸SET and MAP files are provided with the GTAP-EG archive. An aggregation to `aspen_small.zip` is done automatically if you run `aspen.bat`

- [11] McDougall, R. "The GTAP Database", *Draft documentation*. See the GTAP 4 release (<http://www.agecon.purdue.edu/gtap/database>).
- [12] Rutherford, T.F. "Applied General Equilibrium Modeling with MPSGE as a GAMS Subsystem: An overview of the Modeling Framework and Syntax", *Computational Economics*, V.14, Nos. 1-2, 1999.
- [13] Rutherford, T.F. "GTAPinGAMS: The Dataset and Static Model", University of Colorado Department of Economics, 1998.
- [14] Rutherford, T.F. and S.V.Paltsev, "GTAP-EG: Incorporating energy statistics into GTAP format", University of Colorado Department of Economics, 2000.
- [15] United Nations,

Appendix 1. Annex-B countries

Appendix 1 presents Annex B countries as they are identified in the full GTAP-EG dataset.

AUS	Australia
NZL	New Zealand
JPN	Japan
CAN	Canada
CEA	Central European Associates
USA	United States of America
GBR	United Kingdom
DEU	Germany
DNK	Denmark
SWE	Sweden
FIN	Finland
REU	Rest of EU,
EFT	European Free Trade Area
FSU	Former Soviet Union

CEA includes Bulgaria, Czech Republic, Hungary, Poland, Romania, Slovakia, and Slovenia. REU includes Austria, Belgium, Spain, France, Gibraltar, Greece, Ireland, Italy, Luxembourg, Netherlands, and Portugal. EFT includes Switzerland, Iceland, and Norway. FSU includes Armenia, Azerbaijan, Belarus, Estonia, Georgia, Kazakhstan, Kyrgyzstan, Lithuania, Latvia, Moldova, Russia, Tajikistan, Turkmenistan, Ukraine, and Uzbekistan.

Appendix 2. Aggregation of IEA regions into GTAP format

Austria	REU_AUT	Rest of European Union	REU
Belgium	REU_BEL	Rest of European Union	REU
Spain	REU_ESP	Rest of European Union	REU
France	REU_FRA	Rest of European Union	REU
Gibraltar	REU_GIB	Rest of European Union	REU
Greece	REU_GRC	Rest of European Union	REU
Ireland	REU_IRL	Rest of European Union	REU
Italy	REU_ITA	Rest of European Union	REU
Luxembourg	REU_LUX	Rest of European Union	REU
Netherlands	REU_NLD	Rest of European Union	REU
Portugal	REU_PRT	Rest of European Union	REU
Switzerland	EFT_CHE	European Free Trade Area	EFT
Iceland	EFT_ISL	European Free Trade Area	EFT
Norway	EFT_NOR	European Free Trade Area	EFT
Bulgaria	CEA_BGR	Central European Associates	CEA
Czech Republic	CEA_CZE	Central European Associates	CEA
Hungary	CEA_HUN	Central European Associates	CEA
Poland	CEA_POL	Central European Associates	CEA
Romania	CEA_ROM	Central European Associates	CEA
Slovakia	CEA_SVK	Central European Associates	CEA
Slovenia	CEA_SVN	Central European Associates	CEA
Armenia	FSU_ARM	Former Soviet Union	FSU
Azerbaijan	FSU_AZE	Former Soviet Union	FSU
Belarus	FSU_BLR	Former Soviet Union	FSU
Estonia	FSU_EST	Former Soviet Union	FSU
Georgia	FSU_GEO	Former Soviet Union	FSU
Kazakhstan	FSU_KAZ	Former Soviet Union	FSU
Kyrgyzstan	FSU_KGZ	Former Soviet Union	FSU
Lithuania	FSU_LTU	Former Soviet Union	FSU
Latvia	FSU_LVA	Former Soviet Union	FSU
Moldova	FSU_MDA	Former Soviet Union	FSU
Russia	FSU_RUS	Former Soviet Union	FSU
Tajikistan	FSU_TJK	Former Soviet Union	FSU
Turkmenistan	FSU_TKM	Former Soviet Union	FSU
Ukraine	FSU_UKR	Former Soviet Union	FSU
Uzbekistan	FSU_UZB	Former Soviet Union	FSU
Turkey	TUR	Turkey	TUR
United Arab Emirates	RME_ARE	Rest of Middle East	RME
Bahrain	RME_BHR	Rest of Middle East	RME
Iran	RME_IRN	Rest of Middle East	RME
Iraq	RME_IRQ	Rest of Middle East	RME
Israel	RME_ISR	Rest of Middle East	RME
Jordan	RME_JOR	Rest of Middle East	RME
Kuwait	RME_KWT	Rest of Middle East	RME
Lebanon	RME_LBN	Rest of Middle East	RME
Oman	RME_OMN	Rest of Middle East	RME
Qatar	RME_QAT	Rest of Middle East	RME
Saudi Arabia	RME_SAU	Rest of Middle East	RME
Syria	RME_SYR	Rest of Middle East	RME
Yemen	RME_YEM	Rest of Middle East	RME

KEN
 Rest of South-Saharan Africa

	Morocco	MAR	Morocco	MAR
	Algeria	RNF_DZA	Rest of North Africa	RNF
	Egypt	RNF_EGY	Rest of North Africa	RNF
	Libya	RNF_LBY	Rest of North Africa	RNF
	Tunisia	RNF_TUN	Rest of North Africa	RNF
	South Africa CU	SAF	South Africa	SAF
	Angola	RSA_AGO	Rest of South Africa	RSA
	Mozambique	RSA_MOZ	Rest of South Africa	RSA
	Tanzania	RSA_TZA	Rest of South Africa	RSA
	Zambia	RSA_ZMB	Rest of South Africa	RSA
	Zimbabwe	RSA_ZWE	Rest of South Africa	RSA
	Benin	RSS_BEN	Rest of South-Saharan Africa	RSS
Rest of South-Saharan Africa	Comoros	RSS_CIV	Rest of South-Saharan Africa	RSS
	Cameroon	RSS_CMR	Rest of South-Saharan Africa	RSS
	Congo	RSS_COG	Rest of South-Saharan Africa	RSS
	Ethiopia	RSS_ETH	Rest of South-Saharan Africa	RSS
	Gabon	RSS_GAB	Rest of South-Saharan Africa	RSS
	Ghana	RSS_GHA	Rest of South-Saharan Africa	RSS
	Kenya	RSS_KEN	Rest of South-Saharan Africa	RSS
	Nigeria	RSS_NGA	Rest of South-Saharan Africa	RSS

r[(Res375.20 -168.77 m0)-330 -144

RESN

r[(Rest)-330 -180.72 m393.30 -252.45 | BT 284S BT -105udaabon

Appendix 3. An aggregation of production sectors into GTAP-EG format

Appendix 3 describes the mapping of IEA and GTAP 4 production sectors into GTAP-EG format. For more details, see Rutherford and Paltsev [2000] where the process of incorporating of IEA statistics into GTAP-EG is described. The original IEA statistics has 35 sectors. The following table presents a concordance between IEA and GTAP-EG production sectors.

IEA code	Sector	GTAP-EG sector
COL	Coal	COL
AGR	agriculture	AGR
CNS	Construction	CNS
CRP	Chemical and Petrochemical	CRP
DWE	Dwellings	DWE and national consumption (?)
ELY	Electricity	ELE
EXPORTS	Exports	goes to export data
FPR	Food and Tobacco	FRP
GAS	Gas	GAS
HEAT	Heat	Not used
I_S	Iron and steel	I_S
IMPORTS	Imports	goes to import data
INDPROD	Indigenous production	Not used
LUM	Wood products	LUM
NEINTREN	Non energy use in industry	CRP
NEOTHER	Non-energy use in other sectors	AGR
NETRANS	Non-energy use in transport	T_T
NFM	Non ferrous metals	NFM
NMM	Non metallic minerals	NMM
NONROAD	Other (non road) transport	T_T
OIL	Oil	CRU
OME	Machinery	OME
OMF	Other manufacturing	OMF
OMN	Mining	OMN
OWNUSE	Ownuse	Not used
P_C	Petroleum	OIL
PPP	Paper, Pulp, and Print	PPP
RENEW	Renewable	Not used
ROAD	Road	Part to T_T and part to national consumption
SER	Services	SER
TRN	Transport equipment	TRN
TWL	Textile and leather	TWL

An aggregation of GTAP 4 into GTAP-EG is done with the aggregation routine gtapaggr, described in Section 4. The following table shows the mapping.

GTAP 4	GTAP-EG	Sector
GDT, GAS	GAS	Natural gas works
ELY	ELE	Electricity and heat
P_C	OIL	Refined oil products
COL	COL	Coal transformation
OIL	CRU	Crude oil
I.S	I.S	Iron and steel industry
CRP	CRP	Chemical industry
NFM	NFM	Non-ferrous metals
NMM	NMM	Non-metallic minerals
MVH, OTN	TRN	Transport equipment
ELE, OME, FMP	OME	Other machinery
OMN	OMN	Mining
OMT, VOL, MIL, PCR, SGR, OFD, B.T, CMT	FPR	Food products
PPP	PPP	Paper-pulp-print
LUM	LUM	Wood and wood-products
CNS	CNS	Construction
TEX, WAP, LEA	TWL	Textiles-wearing apparel-leather
OMF, WTR	OMF	Other manufacturing
PDR, WHT, GRO, V.F, OSD, C.B, PFB, OCR, CTL, OAP, RMK, WOL, FRS, FSH	AGR	Agricultural products
T_T	T_T	Trade and transport
OSP, OSG	SER	Commercial and public services
DWE	DWE	Dwellings
CGD	CGD	Investment composite

Appendix 4. GTAP-EG: Basic statistics

Table A.4.1. Economic activity by sector

	gdp	gdp%	trade	trade%
DWE	104.0	4.1		
ELE	93.8	3.7		
CNS	159.9	6.3	2.2	0.4
COL	12.0	0.5	2.3	0.4
GAS	14.6	0.6	3.2	0.5
NMM	21.0	0.8	7.3	1.2
OIL	18.4	0.7	8.5	1.4
OMN	5.8	0.2	9.1	1.5
LUM	19.1	0.7	11.0	1.8
NFM	5.5	0.2	11.3	1.8
OMF	25.5	1.0	15.3	2.5
PPP	41.6	1.6	16.1	2.6
I_S	20.6	0.8	18.5	3.0
CRU	37.1	1.5	21.3	3.4
AGR	120.3	4.7	25.9	4.2
FPR	76.0	3.0	35.1	5.6
TWL	44.2	1.7	46.4	7.5
SER	892.3	35.0	46.4	7.5
T_T	505.5	19.8	53.3	8.6
TRN	55.0	2.2	58.0	9.3
CRP	84.4	3.3	64.1	10.3
OME	190.9	7.5	165.8	26.7

Table A.4.2. Economic activity by region

	gdp	gdp%	trade	trade%
RSM	0.4	0.0	0.4	0.1
URY	1.4	0.1	0.4	0.1
LKA	1.2	0.0	0.5	0.1
VNM	1.2	0.0	0.7	0.1
MAR	2.6	0.1	1.0	0.2
COL	6.9	0.3	1.5	0.2
RSA	1.6	0.1	1.5	0.2
RAP	7.4	0.3	1.6	0.3
RAS	6.9	0.3	1.7	0.3
CHL	5.5	0.2	2.0	0.3
VEN	6.8	0.3	2.0	0.3
NZL	5.1	0.2	2.2	0.3
PHL	5.9	0.2	2.8	0.4
ARG	24.9	1.0	2.9	0.5
ROW	22.0	0.9	3.3	0.5
SAF	12.7	0.5	3.5	0.6
TUR	15.6	0.6	3.8	0.6
RNF	10.7	0.4	3.9	0.6

RSS	13.6	0.5	4.3	0.7
CAM	7.2	0.3	4.4	0.7
IND	27.7	1.1	4.4	0.7
FIN	11.6	0.5	4.9	0.8
IDN	19.6	0.8	5.7	0.9
BRA	62.9	2.5	6.2	1.0
DNK	15.5	0.6	6.4	1.0
AUS	31.8	1.2	7.2	1.2
THA	14.9	0.6	7.5	1.2
HKG	9.9	0.4	8.2	1.3
MEX	25.2	1.0	8.9	1.4
SWE	19.3	0.8	9.2	1.5
MYS	7.1	0.3	9.3	1.5
FSU	44.8	1.8	11.4	1.8
CEA	27.8	1.1	11.7	1.9
SGP	6.0	0.2	13.3	2.1
TWN	24.6	1.0	15.1	2.4
RME	39.8	1.6	15.8	2.5
KOR	39.7	1.6	16.0	2.6
EFT	40.8	1.6	16.6	2.7
CAN	49.7	2.0	21.1	3.4
CHN	55.5	2.2	23.7	3.8
GBR	101.3	4.0	29.6	4.8
JPN	463.1	18.2	54.3	8.7
DEU	222.1	8.7	58.6	9.4
USA	655.8	25.7	79.5	12.8
REU	372.0	14.6	132.2	21.3

Table A.4.3. Carbon inventories -- mton

	total	ind_nele	fd_nele	electric	ind_total	fd_total	kg/\$
AUS	78.0	33.2	9.8	35.0	60.8	17.1	0.2
NZL	8.8	6.8	1.2	0.8	7.4	1.4	0.2
JPN	342.8	198.3	54.8	89.7	269.7	73.0	0.1
KOR	122.4	83.5	18.0	20.9	101.4	21.0	0.3
IDN	64.0	40.3	12.3	11.5	48.8	15.2	0.3
MYS	23.1	12.8	3.7	6.6	18.4	4.6	0.3
PHL	12.2	7.2	1.9	3.1	9.7	2.5	0.2
SGP	23.2	16.8	0.8	5.6	21.6	1.6	0.4
THA	38.4	18.2	8.2	12.0	28.1	10.3	0.3
VNM	5.4	4.0	0.6	0.8	4.6	0.8	0.5
CHN	848.8	534.0	78.5	236.4	745.1	103.7	1.6
HKG	13.8	7.5	0.4	5.8	12.2	1.6	0.1
TWN	49.8	28.9	4.8	16.1	42.1	7.7	0.2
IND	210.9	88.1	26.4	96.4	172.4	38.5	0.8
LKA	2.1	1.7	0.3	0	1.7	0.3	0.2
RAS	27.4	14.8	5.5	7.1	20.3	7.1	0.4
CAN	138.1	83.9	28.6	25.6	104.1	34.0	0.3
USA	1489.2	613.2	337.1	539.0	1014.5	474.8	0.2
MEX	89.6	54.5	16.3	18.8	70.1	19.5	0.4

CAM	27.2	17.5	2.7	7.0	23.5	3.8	0.4
VEN	33.1	22.2	5.8	5.1	26.4	6.7	0.5
COL	17.8	10.8	4.1	2.9	12.9	4.8	0.3
RAP	13.8	9.8	2.5	1.5	11.0	2.7	0.2
ARG	33.4	15.6	12.2	5.6	20.0	13.4	0.1
BRA	78.9	61.5	14.1	3.3	64.2	14.7	0.1
CHL	11.3	6.9	2.6	1.9	8.5	2.8	0.2
URY	1.6	1.2	0.3	0	1.3	0.3	0.1
RSM	0.9	0.4	0.5	0	0.4	0.5	0.2
GBR	165.6	84.9	37.4	43.3	117.9	47.7	0.2
DEU	265.4	118.4	64.4	82.6	184.2	81.2	0.1
DNK	18.6	7.7	2.7	8.2	13.9	4.7	0.1
SWE	17.5	11.1	4.4	2.1	12.6	4.9	0.1
FIN	16.2	8.4	2.4	5.4	12.7	3.5	0.1
REU	473.1	267.7	106.9	98.5	346.6	126.4	0.1
EFT	25.3	17.5	7.4	0.3	17.8	7.5	0.1
CEA	208.1	91.3	25.0	91.8	167.2	40.9	0.8
FSU	695.1	324.6	72.3	298.2	576.6	118.5	1.7
TUR	45.9	27.5	7.1	11.3	37.0	8.9	0.3
RME	225.6	133.4	39.4	52.8	175.2	50.4	0.6
MAR	7.3	3.7	1.0	2.7	5.7	1.6	0.3
RNF	56.5	32.3	9.2	15.1	44.5	12.1	0.5
SAF	96.0	44.1	10.9	41.0	79.8	16.2	0.8
RSA	7.2	4.5	0.6	2.1	6.3	0.9	0.5
RSS	22.7	16.0	4.4	2.3	17.9	4.8	0.2
ROW	56.8	32.0	5.6	19.2	47.2	9.6	0.3
total	6208.5	3218.4	1054.9	1935.1	4784.3	1424.1	

	as % of non-annex	as % of total
KOR	5.398	1.971
IDN	2.824	1.031
MYS	1.018	0.372
PHL	0.539	0.197
SGP	1.023	0.374
THA	1.694	0.618
VNM	0.237	0.086
CHN	37.446	13.672
HKG	0.607	0.222
TWN	2.195	0.801
IND	9.303	3.397
LKA	0.091	0.033
RAS	1.207	0.441
MEX	3.951	1.442
CAM	1.202	0.439
VEN	1.460	0.533
COL	0.784	0.286
RAP	0.608	0.222
ARG	1.471	0.537
BRA	3.479	1.270
CHL	0.501	0.183
URY	0.070	0.025
RSM	0.039	0.014
TUR	2.024	0.739
RME	9.954	3.634
MAR	0.322	0.118
RNF	2.495	0.911
SAF	4.235	1.546
RSA	0.316	0.115
RSS	1.003	0.366
ROW	2.504	0.914
non-annex b	100.000	36.512

Table A.4.5. Carbon dioxide emissions - billion of tonnes

	IEA book	IEA stat	GTAP-E-FIT	EG with no fix	GTAP-EG
AUS	0.286	0.286	0.283	0.286	0.286
NZL	0.029	0.032	0.033	0.032	0.032
JPN	1.151	1.208	1.145	1.257	1.257
KOR	0.353	0.449	0.396	0.449	0.449
IDN	0.227	0.235	0.212	0.235	0.235
MYS	0.092	0.085	0.084	0.085	0.085
PHL	0.050	0.045	0.044	0.045	0.045
SGP	0.059	0.085	0.085	0.085	0.085

THA	0.156	0.140	0.140	0.141	0.141
VNM	0.022	0.020	0.021	0.020	0.020
CHN	3.007	3.098	2.902	3.112	3.112
HKG	0.044	0.052	0.052	0.050	0.050
TWN	0.167	0.182	0.179	0.182	0.182
IND	0.803	0.771	0.765	0.773	0.773
LKA	0.006	0.008	0.007	0.008	0.008
RAS	0.211	0.100	0.097	0.100	0.100
CAN	0.471	0.505	0.472	0.506	0.506
USA	5.228	5.339	5.175	5.340	5.460
MEX	0.328	0.328	0.309	0.328	0.328
CAM	0.111	0.097	0.100	0.100	0.100
VEN	0.113	0.114	0.112	0.121	0.121
COL	0.065	0.063	0.062	0.065	0.065
RAP	0.052	0.050	0.047	0.051	0.051
ARG	0.128	0.121	0.115	0.122	0.122
BRA	0.287	0.269	0.256	0.289	0.289
CHL	0.042	0.042	0.039	0.042	0.042
URY	0.005	0.006	0.006	0.006	0.006
RSM	0.003	0.003	0.004	0.003	0.003
GBR	0.565	0.605	0.540	0.607	0.607
DEU	0.884	0.973	0.865	0.973	0.973
DNK	0.060	0.067	0.063	0.068	0.068
SWE	0.056	0.064	0.061	0.064	0.064
FIN	0.054	0.059	0.057	0.059	0.059
REU	1.560	1.734	1.628	1.735	1.735
EFT	0.078	0.093	0.082	0.093	0.093
CEA	0.749	0.762	0.707	0.763	0.763
FSU	2.483	2.542	2.341	2.549	2.549
TUR	0.160	0.168	0.156	0.168	0.168
RME	0.817	0.788	0.755	0.827	0.827
MAR	0.026	0.027	0.026	0.027	0.027
RNF	0.213	0.204	0.201	0.207	0.207
SAF	0.321	0.347	0.337	0.352	0.352
RSA	0.025	0.026	0.026	0.026	0.026
RSS	0.081	0.083	0.103	0.083	0.083
ROW	0.518	0.208	0.183	0.208	0.208
total	22.150	22.482	21.272	22.644	22.764

Appendix 5. MPSGE formulation

Appendix 5 presents the function declarations for GTAP-EG model implemented in MPSGE.

```
*      Final demand
$prod:c(r)  s:0.5 c:1 e:1  oil(e):0 col(e):0 gas(e):0
o:pc(r)    q:ct0(r)
i:pa(i,r) q:c0(i,r) p:pc0(i,r) i.tl:$fe(i) c:$not e(i) e:$ele(i) a:ra(r) t:tc(i,r)
```

```

+          oil(lqd):0 col(nel):0 gas(lqd):0

o:py(i,r)      q:vom(i,r)  a:ra(r)  t:ty(i,r)
i:pa(j,r)$(not fe(j)) q:vafm(j,i,r) p:pai0(j,i,r) e:$ele(j) a:ra(r) t:ti(j,i,r)
i:pl(r)        q:ld0(i,r)          va:
i:rkr(r)$rsk  q:kd0(i,r)          va:
i:rkg$gk      q:kd0(i,r)          va:
i:pcarb(r)#(fe) q:carbcoef(fe,i,r) p:1e-6 fe.tl:
i:pa(fe,r)    q:vafm(fe,i,r) p:pai0(fe,i,r) fe.tl: a:ra(r) t:ti(fe,i,r)

*      Fossil fuel production activity (crude, gas and coal):
$prod:y(xe,r)$vom(xe,r) s:(esub_es(xe,r)) id:0
o:py(xe,r)      q:vom(xe,r)  a:ra(r)  t:ty(xe,r)
i:pa(j,r)      q:vafm(j,xe,r) p:pai0(j,xe,r) a:ra(r) t:ti(j,xe,r) id:
i:pl(r)        q:ld0(xe,r)  id:
i:pr(xe,r)    q:rd0(xe,r)

*      Armington aggregation over domestic versus imports:
$prod:a(i,r)$a0(i,r) s:4 m:8 s.tl(m):0
o:pa(i,r)      q:a0(i,r)
i:py(i,r)      q:d0(i,r)
i:py(i,s)      q:vxmd(i,s,r) p:pmx0(i,s,r) s.tl:
+          a:ra(s) t:tx(i,s,r) a:ra(r) t:(tm(i,s,r)*(1+tx(i,s,r)))
i:pt#(s)      q:vtwr(i,s,r) p:pmt0(i,s,r) s.tl: a:ra(r) t:tm(i,s,r)

*      International transport services (Cobb-Douglas):

$prod:yt s:1
o:pt          q:(sum((i,r), vst(i,r)))
i:py(i,r)    q:vst(i,r)

*      Final demand:
$demand:ra(r)
d:pc(r)      q:ct0(r)
e:py("cgd",r) q:-vom("cgd",r)
e:rkr(r)$rsk q:(sum(i, kd0(i,r)))
e:rkg$gk     q:(sum(i, kd0(i,r)))
e:pl(r)      q:evoa("lab",r)
e:pr(xe,r)   q:rd0(xe,r)
e:pc("usa")  q:vb(r)
e:pcarb(r)   q:carblim(r)

```

Appendix 6. ASPEN_SMALL.SET

\$TITLE Set Definitions for 13 regions and 8 goods

```

SET I Sectors/
Y Other manufactures and services
EIS Energy-intensive sectors
COL Coal

```

OIL Petroleum and coal products (refined)
CRU Crude oil
GAS Natural gas
ELE Electricity
CGD Savings good/;

SET R Aggregated Regions /
USA United States
CAN Canada
EUR Europe
JPN Japan
OOE Other OECD
FSU Former Soviet Union
CEA Central European Associates
CHN China (including Hong Kong + Taiwan)
IND India
BRA Brazil
ASI Other Asia
MPC Mexico + OPEC
ROW Rest of world /

Set F Aggregated factors /
LAB Labor,
CAP Capital /;

Appendix 7. ASPEN_SMALL.MAP

\$title Map file

* Aggregating ASPEN dataset (45x23) into ASPEN_SMALL dataset (13x8)

* -----
* The target dataset has fewer sectors, so we need to specify how
* each sector in the source dataset is mapped to a sector in the
* target dataset:

\$SETGLOBAL source aspen

Set mapi Sectors and goods /

GAS.GAS Natural gas works
ELE.ELE Electricity and heat
OIL.OIL Refined oil products
COL.COL Coal transformation
CRU.CRU Crude oil

I_S.EIS Iron and steel industry (IRONSTL)
CRP.EIS Chemical industry (CHEMICAL)
NFM.EIS Non-ferrous metals (NONFERR)
NMM.EIS Non-metallic minerals (NONMET)

TRN. EIS Transport equipment (TRANSEQ)

EFT. EUR European Free Trade Area
CEA. CEA Central European Associates
FSU. FSU Former Soviet Union
TUR. ROW Turkey
RME. MPC Rest of Middle East
MAR. ROW Morocco
RNF. MPC Rest of North Africa
SAF. ROW South Africa
RSA. ROW Rest of South Africa
RSS. ROW Rest of South-Saharan Africa
ROW. ROW Rest of World /;

* The following statements illustrate how to aggregate
* factors of production in the model. Unlike the aggregation
* of sectors or regions, you need to declare the set of
* primary in the source as set FF, then you can specify the
* mapping from the source to the target sets.

```
set ff /LND, SKL, LAB, CAP, RES/;  
SET MAPF mapping of primary factors /LND. CAP, SKL. LAB, LAB. LAB, CAP. CAP, RES. CAP/;
```